

Client	
Projet	
Date	
Offre	

Date livraison	
Adresse	
CP	
Ville	
Contact	
Portable	
Mail	

--

Nature de la prestation <input type="checkbox"/> Monté <input type="checkbox"/> Montage chez client <input type="checkbox"/> Franco		Document à fournir (O=offre ; P=produit ; X=O+P) <input type="checkbox"/> Aucun <input type="checkbox"/> Plan <input type="checkbox"/> Nomenclature <input type="checkbox"/> Schémas de montage <input type="checkbox"/> Autres (préciser)	
--	--	---	--

Charge maxi sur convoyeur : Kg Poids du produit : Kg

Dimensions Longueur hors-tout : mm

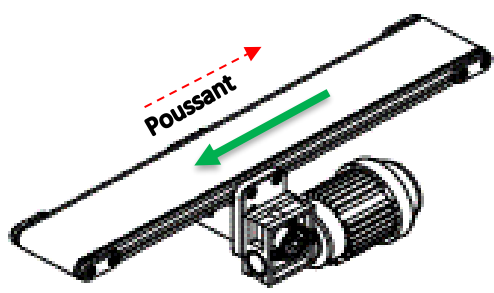
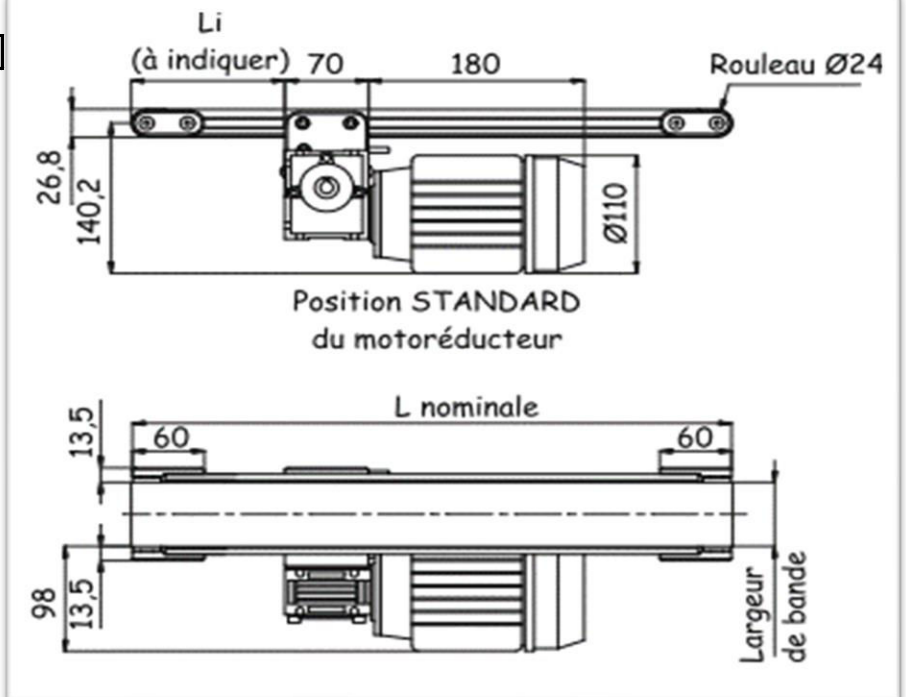
Entrainement <input type="checkbox"/> Intermédiaire <input type="checkbox"/> Cote Li = <input type="text"/> mm	Largeur bande (En mm):	<table border="1"> <tr><td>20</td><td>40</td><td>60</td><td>80</td><td>100</td></tr> <tr><td><input type="checkbox"/></td><td><input type="checkbox"/></td><td><input type="checkbox"/></td><td><input type="checkbox"/></td><td><input type="checkbox"/></td></tr> <tr><td>2442</td><td>2444</td><td>2446</td><td>2448</td><td>2440</td></tr> </table>	20	40	60	80	100	<input type="checkbox"/>	<input type="checkbox"/>	<input type="checkbox"/>	<input type="checkbox"/>	<input type="checkbox"/>	2442	2444	2446	2448	2440
20	40	60	80	100													
<input type="checkbox"/>	<input type="checkbox"/>	<input type="checkbox"/>	<input type="checkbox"/>	<input type="checkbox"/>													
2442	2444	2446	2448	2440													

Position moteur Moteur Vertical Moteur Horizontal

Vitesse en m/min	1,8	2,2	2,7	3,6	5,4	7,2	10,9	14,5	21,7
	<input type="checkbox"/>	<input type="checkbox"/>	<input type="checkbox"/>	<input type="checkbox"/>	<input type="checkbox"/>	<input type="checkbox"/>	<input type="checkbox"/>	<input type="checkbox"/>	<input type="checkbox"/>
	2400	2401	2402	2403	2404	2405	2406	2407	2408

Type de Bande <input type="checkbox"/> Bande PU lisse basique verte <input type="checkbox"/> Bande PVC alimentaire blanc	<table border="1"> <tr><td>20</td><td>40</td><td>60</td><td>80</td><td>100</td></tr> <tr><td><input type="checkbox"/></td><td><input type="checkbox"/></td><td><input type="checkbox"/></td><td><input type="checkbox"/></td><td><input type="checkbox"/></td></tr> <tr><td>2472</td><td>2474</td><td>2476</td><td>2478</td><td>2470</td></tr> <tr><td><input type="checkbox"/></td><td><input type="checkbox"/></td><td><input type="checkbox"/></td><td><input type="checkbox"/></td><td><input type="checkbox"/></td></tr> <tr><td>2462</td><td>2464</td><td>2466</td><td>2468</td><td>2460</td></tr> </table>	20	40	60	80	100	<input type="checkbox"/>	<input type="checkbox"/>	<input type="checkbox"/>	<input type="checkbox"/>	<input type="checkbox"/>	2472	2474	2476	2478	2470	<input type="checkbox"/>	<input type="checkbox"/>	<input type="checkbox"/>	<input type="checkbox"/>	<input type="checkbox"/>	2462	2464	2466	2468	2460
20	40	60	80	100																						
<input type="checkbox"/>	<input type="checkbox"/>	<input type="checkbox"/>	<input type="checkbox"/>	<input type="checkbox"/>																						
2472	2474	2476	2478	2470																						
<input type="checkbox"/>	<input type="checkbox"/>	<input type="checkbox"/>	<input type="checkbox"/>	<input type="checkbox"/>																						
2462	2464	2466	2468	2460																						

Jambage

Hauteur bande / sol mm

Réglage +/- mm

Guidage

Supprot Réglable **3700-TB24**

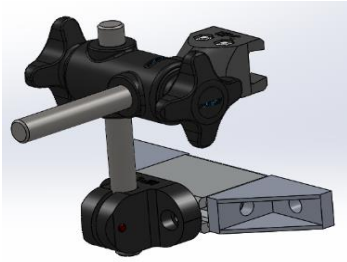

Guide Type **1219**

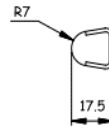

Guide Type **1498**

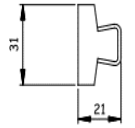

Coffret Electrique

Coffret Electrique Demarrage
direct Triphasé **3710**



Coffret Electrique
Variateur Alim 230V Mono **2831-SP01**

Coffret Electrique
Variateur Alim 400V Tri **2831-SP01-380**



Information complémentaire / Option / Type de Fonctionnement / Accumulation?