

Technical sheet Incline conveyors

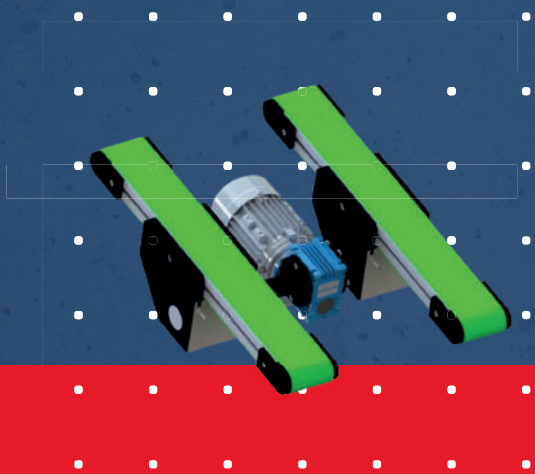

CONVEYOR 40 INCLINED





Conveyors Inclined Type 1

Widths 200, 300, 400 mm

Technical data

Flat belt conveyor with 1 angle for building elevators thanks to cleated belts.

For light parts maxi 8 kg.

Dimensions (mm)

- X Width A: 200 - 300 - 400
- X Length: $L1 + L2 = 4\ 000$ maxi
- X Cleats height: 60 maxi

Gear motors

- X 230V single-phase and 230/400 V three-phase
 - X 24 Vcc on request
- Gear motors data: Page 106

Belts

- X Cleated belts only
- Belt data: Page 104

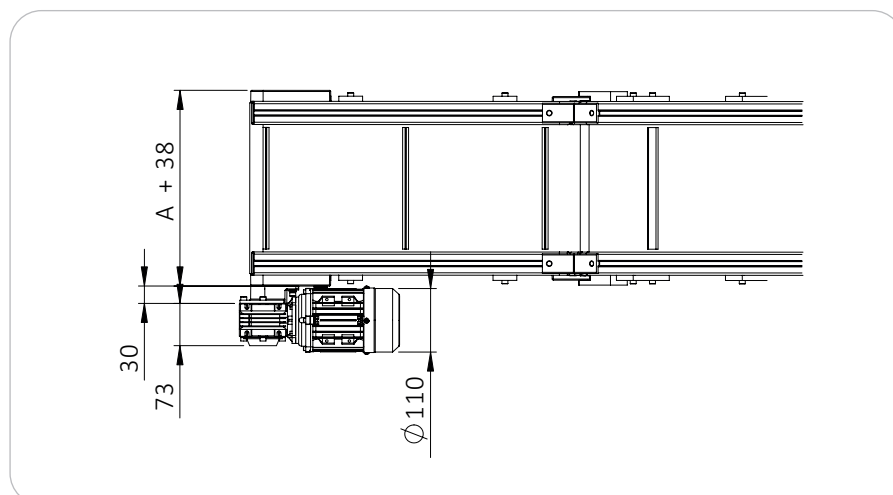
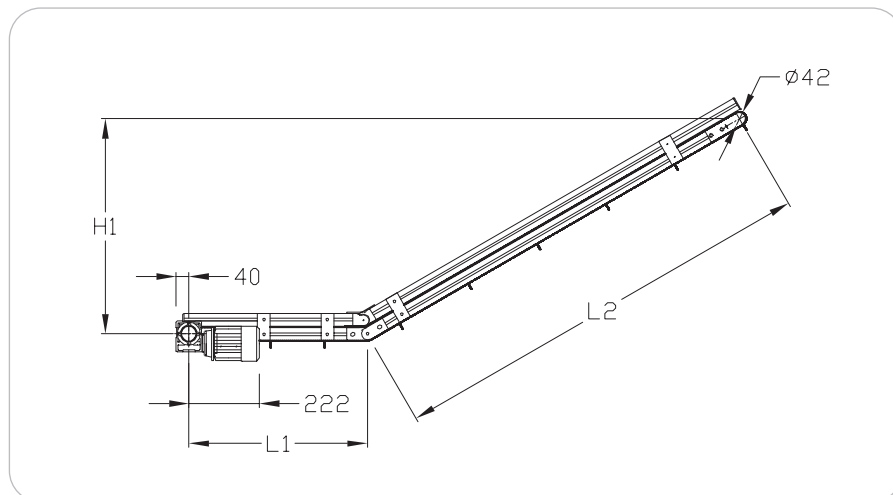



Gear motors positions (see page 106)

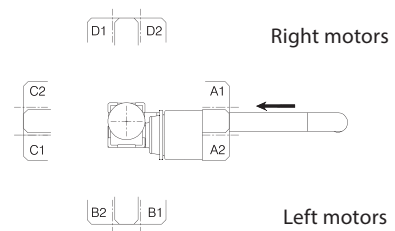

Product description/Dimensions	Order unit	Reference
Conveyor inclined Type 1 Width 200 mm	1 pce	C 200 70 000
Conveyor inclined Type 1 Width 300 mm	1 pce	C 300 70 000
Conveyor inclined Type 1 Width 400 mm	1 pce	C 400 70 000

Conveyors Inclined Type 2

Widths 200, 300, 400 mm

Technical data

Flat belt conveyor with 1 angle for building elevators thanks to cleated belts.

For light parts maxi 8 kg.

Dimensions (mm)

- X Width A: 200 - 300 - 400
- X Length : $L2 + L3 = 4\ 000$ maxi
- X Cleats height: 60 maxi

Gear motors

- X 230V single-phase and 230/400 V three-phase
 - X 24 Vcc on request
- Gear motors data: Page 106

Belts

- X Cleated belts only
- Belt data: Page 104

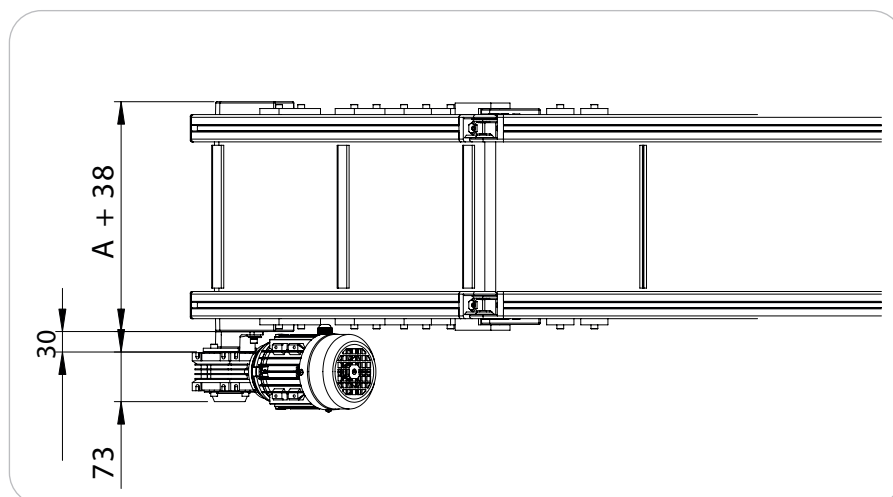
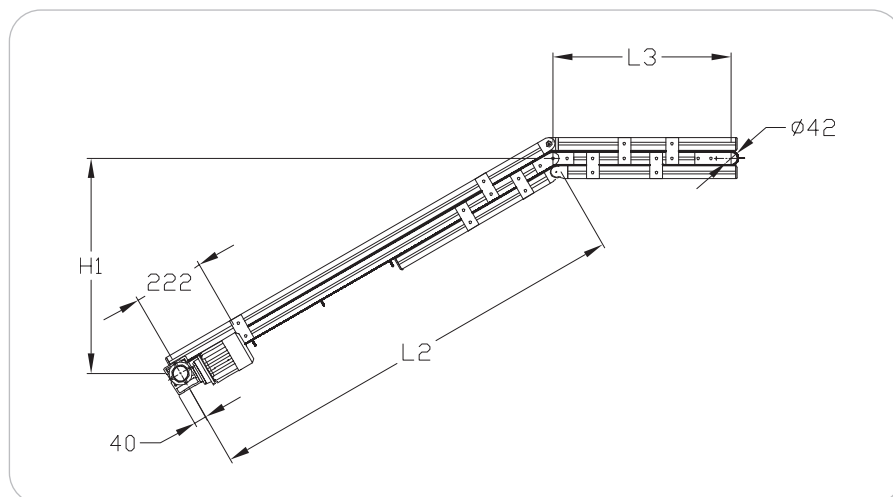

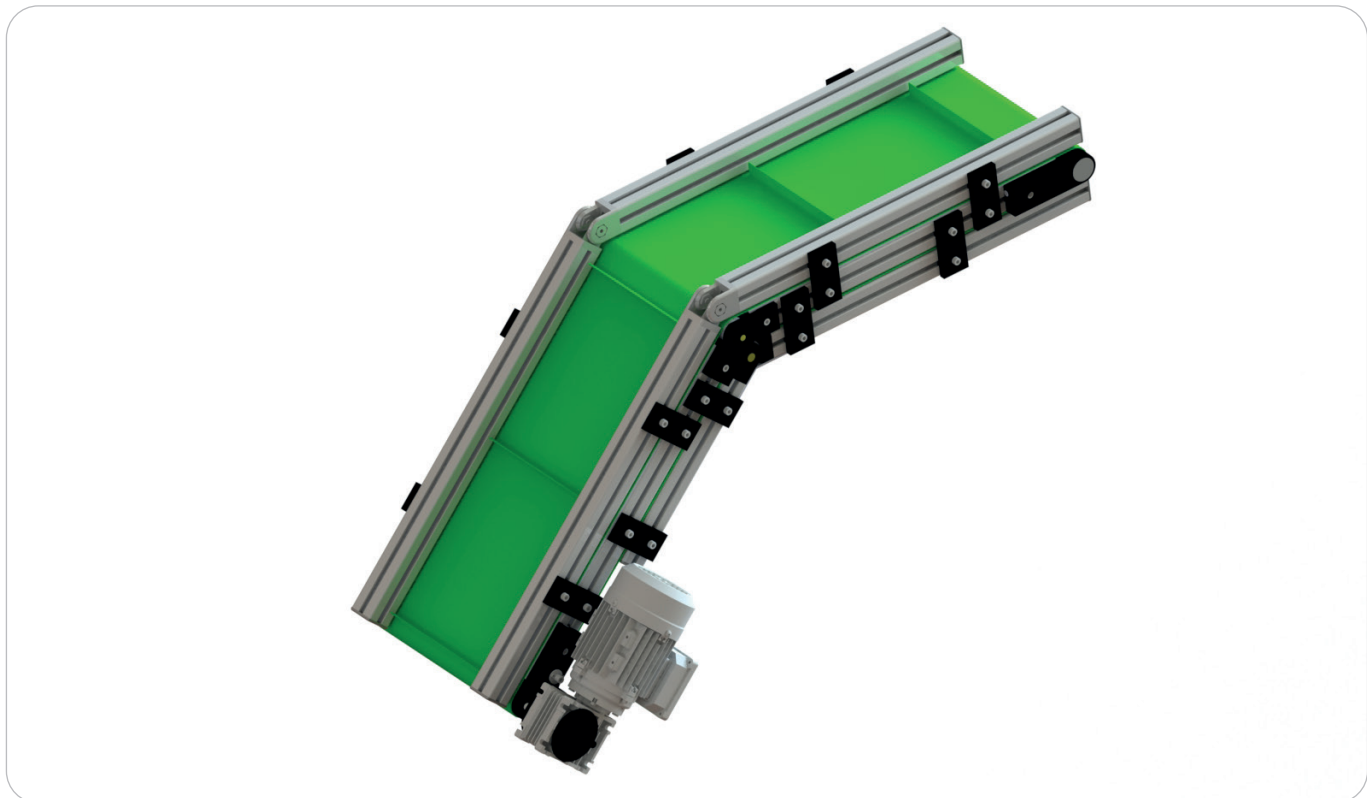

Gear motors positions (see page 106)

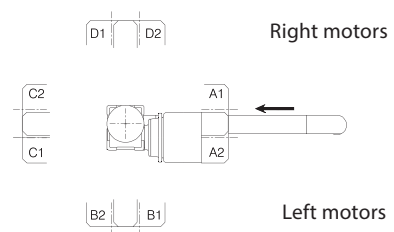

Product description/Dimensions	Order unit	Reference
Conveyor inclined Type 2 Width 200 mm	1 pce	C 200 75 000
Conveyor inclined Type 2 Width 300 mm	1 pce	C 300 75 000
Conveyor inclined Type 2 Width 400 mm	1 pce	C 400 75 000

Conveyors Inclined Type 3

Widths 200, 300, 400 mm

Technical data

Conveyor avec 2 articulations permettant de réaliser des élévateurs de pièces grâce to des bandes to tasseaux.

Adapté aux pièces légères maxi 8 kg.

Dimensions (mm)

- X Width A: 200 - 300 - 400
- X Length : L1 + L2 + L3 = 4 000 maxi
- X Cleats height: 60 maxi

Gear motors

- X 230 V single-phase and 230/400 V three-phase
 - X 24 Vcc on request
- Gear motors data: Page 106

Belts

- X Cleated belts only
- Belt data: Page 104

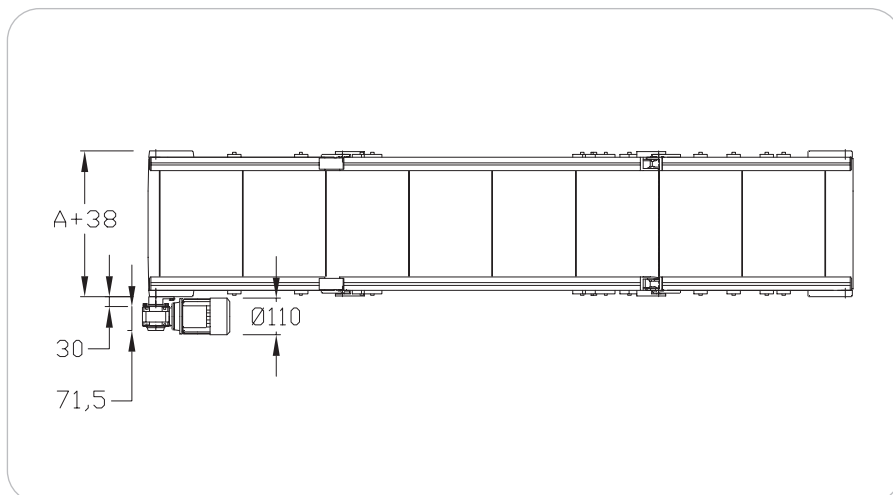
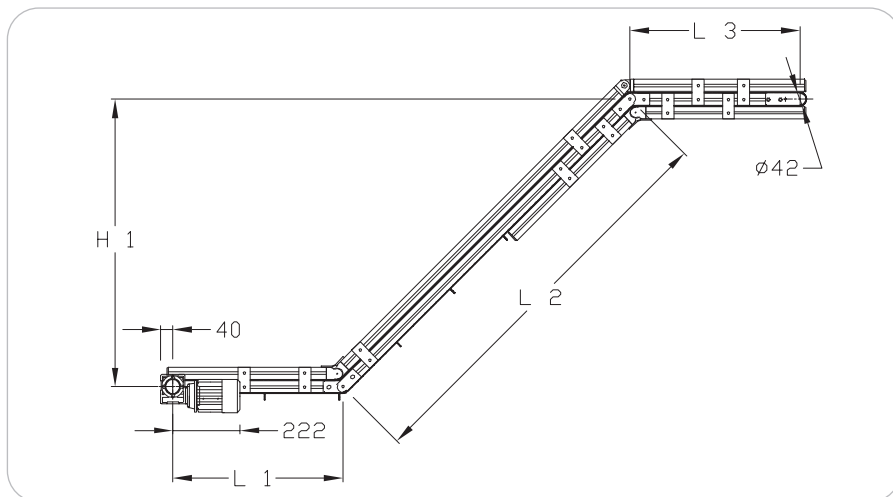

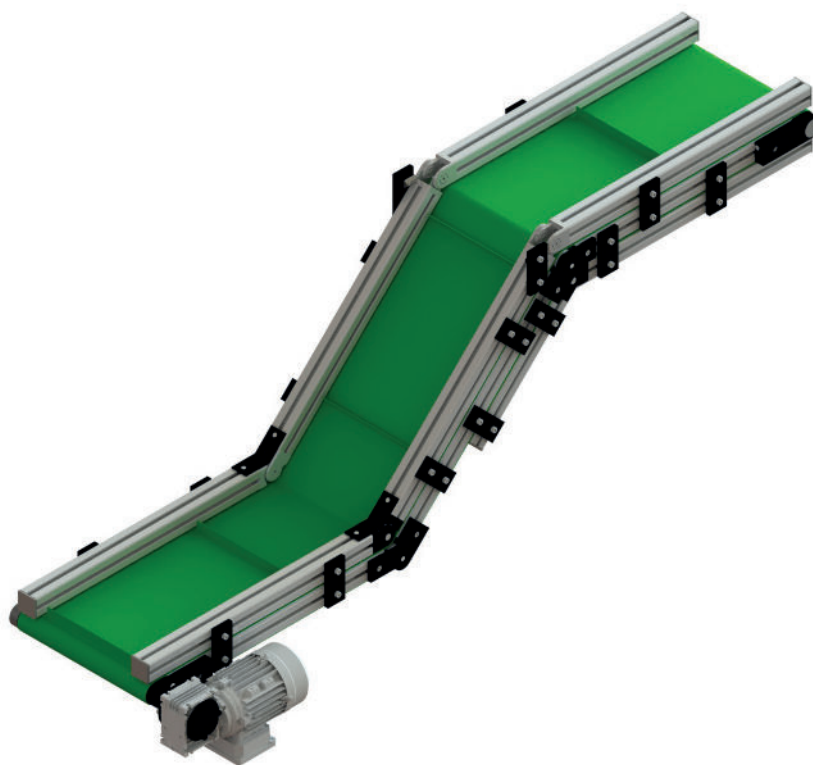

Gear motors positions (see page 106)

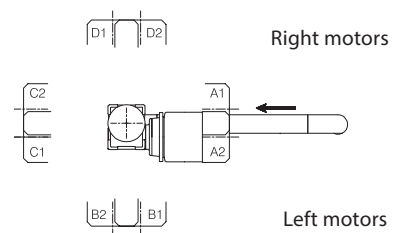

Product description/Dimensions	Order unit	Reference
Conveyor inclined Type 3 Width 200 mm	1 pce	C 200 80 000
Conveyor inclined Type 3 Width 300 mm	1 pce	C 300 80 000
Conveyor inclined Type 3 Width 400 mm	1 pce	C 400 80 000